

FEATURES

- 16-Channels strain gage, bridge or voltage transducers
- Ethernet control and data interface
- Real time temperature compensated (Gain & Excitation) from -20°C to +50°C
- 0.1% or better accuracy over full gain & temperature range
- 100 kHz analog bandwidth, gain 1 to 1,000
- 24-Bit A/D programmable up to 204.8kS/s per channel
- Wide range programmable filter, 80 dB/octave
- IRIG A, B & G time decoding and recording
- 1 μ S synchronized sampling of multiple enclosures
- Ruggedized for tough environments
- 20 to 30 Volt DC power



Pacific's Ruggedized Model 7400 increases the bandwidth and sample rates of the popular 7200 ruggedized data systems. A network appliance, each module conditions, amplifies and digitizes the outputs of up to sixteen strain gage, bridge or voltage transducers. The rugged enclosure is designed for installation in wind tunnels, engine test stands and other facilities where it is desired to locate the DAS close to the test article, ultimately reducing installation and cable costs as well as improving signal quality and reliability.

Fully self-contained, the 7400 provides transducer excitation, bridge completion and balance. The transducer output is amplified, filtered to remove signal components that could produce alias errors and digitized to 24-bit resolution. The digitized transducer output is digitally processed providing multiple sample rates, an 80 dB/octave FIR filter and 32-bit floating point output format in millivolts referred to input, millivolts referred to output or user defined engineering units.

Three models are available that differ in their excitation and signal conditioning capabilities. Model 7416 for strain gage and bridge transducers has programmable voltage excitation, bridge completion for 120 and 350 Ohm strain gages, shunt calibration and automatic balance. Model 7420 is similar but provides regulated power for transducers with internal electronics. Model 7418 is for voltage inputs. The amplified transducer signals are digitized, processed and output at up to 204,800 samples per second, as selected for individual channels. A digital signal processor (DSP) provides low-pass filtering selectable from 10 Hz to 50 kHz with 80 db/octave roll-off.

Each module has a 1 Gigabit Ethernet interface for control and data output, which simplifies system wiring and provides remote and distributed operation. IRIG time may be employed to synchronize sampling on multiple modules within 10 microseconds, or a TTL timing signal may be used to achieve better than 1 microsecond time alignment. Multiple modules with up to 4,096 channels may be connected on a single Ethernet LAN.

The module enclosure features interchangeable end plates that provide fully sealed, ambient air or forced air cooling. Forced air cooling provides the capability to operate over a wide temperature range according to application requirements. Occupying less than 500 cubic inches and weighing less than 14 pounds, the 7400 system can be installed in locations previously not suitable for data acquisition systems. The Ethernet interface and IRIG timing make it easy to distribute modules throughout the test facility, minimizing sensor cabling and installation costs.

The 7400 does not sacrifice performance for size or portability; it features higher accuracy than most systems designed for a laboratory environment. Accuracy is better than 0.05% for gains up to 200 and 0.1% for gains above 200 over the temperature range -20°C to +50°C, which can be extended to higher temperatures by forced air cooling.

Model 7400 is supported by Pacific's PI770 software that provides a ready-to-run application and an SDK for user program development. Calibration and performance verification is accomplished by PANEL72 Maintenance and Calibration software. The ACS2000 Automatic Calibration System automates performance verification and periodic instrument calibration.

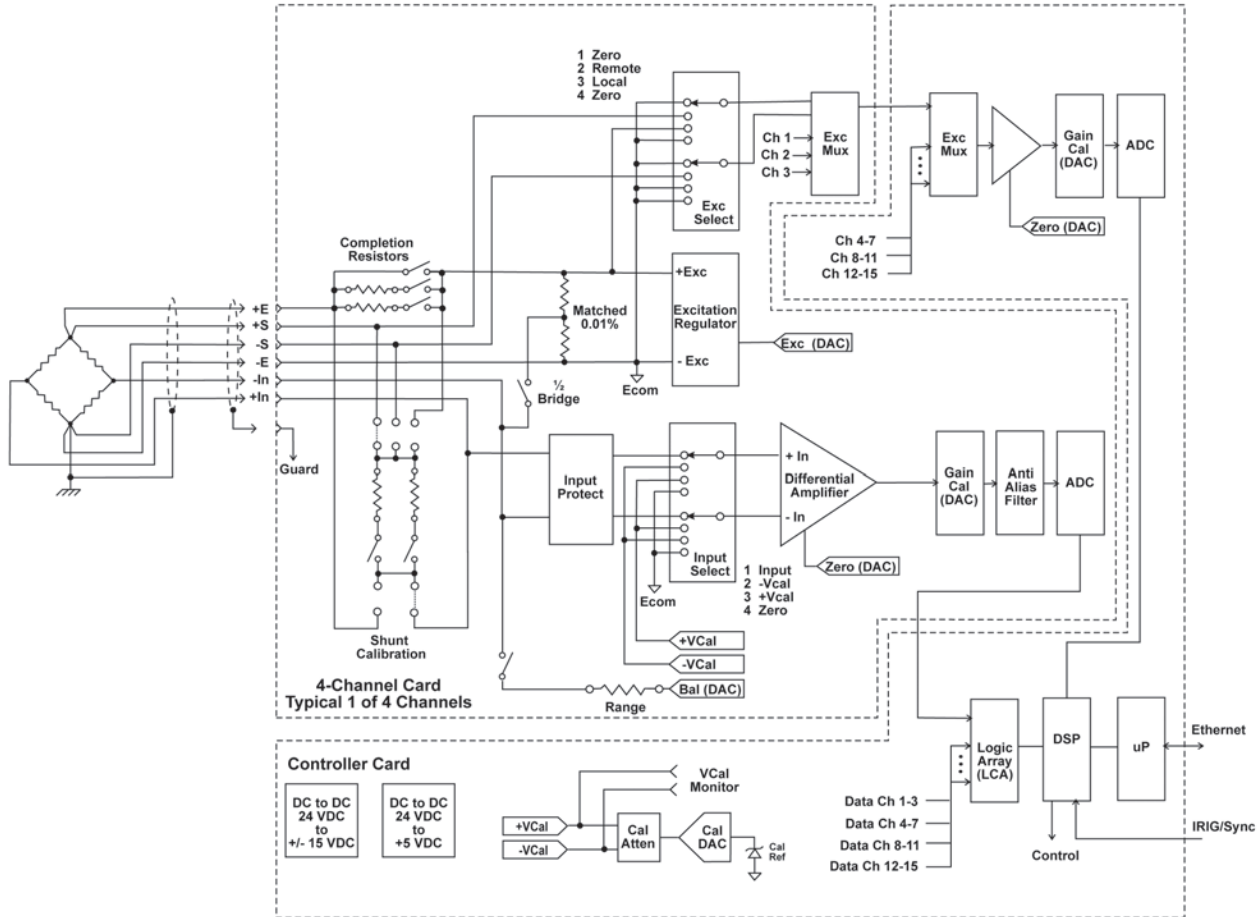

7416 Functional Block Diagram

Cabling transducers to a remote data acquisition system is costly and may require intermediate signal connections that introduce reliability problems. In addition the transducer and cable impedance can filter the signal, attenuating high frequency signal components. Locating data acquisition hardware near

transducers at many test facilities has required specially constructed and environmentally conditioned enclosures. Using the 7400, the data acquisition can be installed in unprepared locations and the only external connections are power, timing and Ethernet.

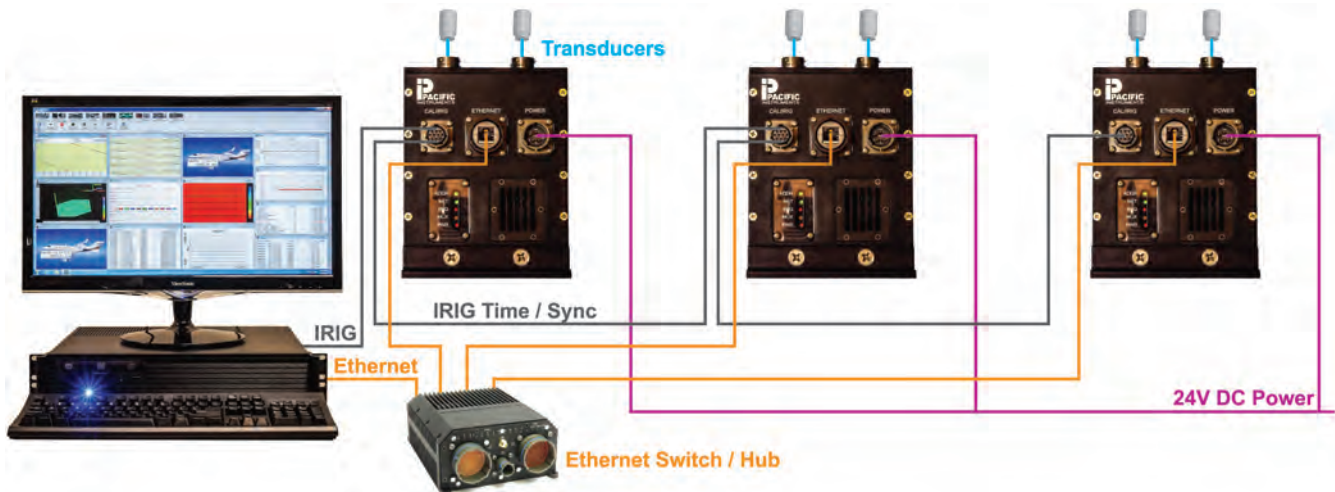

Typical 7400 Installation

ACCURACY

All 7400 models maintains $\pm 0.05\%$ uncertainty for gains up to 200 and $\pm 0.1\%$ for gains above 200 over the full temperature range by continuously correcting for temperature induced excitation, gain and zero deviations. The 7400 modules are calibrated and correction vectors are stored in non-volatile memory. An internal sensor determines the correction vectors applied to the data according to the device temperature. An internal programmable voltage reference can be applied to the channel inputs. The reference voltage can be externally monitored to verify accuracy.

SIGNAL CONDITIONING

The excitation output is programmable from 0 to 15 Volts with better than 1 millivolt resolution. Calibrated 1 Volt $\pm 0.1\%$ steps are also provided. Output current is 50 mA. The excitation voltage is continuously monitored by sense inputs connected to the sensor and automatically adjusts as necessary to maintain a constant voltage over the full temperature range. Bridge completion is programmable for quarter-bridge, 120 and 350 Ohm gages, half and full bridges. Other values can be supplied on request. Two steps of shunt calibration are provided. Transducer balance employs a high-resolution DAC and is initiated by program instruction.

INSTRUMENTATION AMPLIFIER

The sensor inputs are protected up to ± 50 Volts differential and ± 30 Volts common mode. They are applied to a high impedance, programmable gain, differential instrumentation amplifier. The amplifier has programmable gains from 1 to 1,000 providing full-scale input ranges of ± 10 mV to ± 10 Volts. Calibrated gain steps with $\pm 0.02\%$ accuracy are provided or the amplifier gain may be continuously programmed. Autozero maintains the amplifier output offset within ± 1 mV.

ANALOG TO DIGITAL

Conditioned and amplified transducer signals are digitized by a 24-bit resolution Sigma-Delta analog-to-digital converter that over-samples the analog signal enabling the use of a single frequency anti-aliasing filter.

SAMPLING

All channels are simultaneously sampled at the highest sample rate, 204.8 kS/s. Sampling is synchronized between channels and modules providing time aligned data using an external TTL timing signal or IRIG time. The TTL signal distributed to all modules provides 1 μ s time alignment for channels in the same or different modules. Sampling may be synchronized to IRIG A, B or G time. IRIG G time is generated by the unit connected to the external IRIG source or designated as the master time source if external IRIG is not used. Distributed to multiple modules it maintains channel to channel time alignment of 1 μ s for channels in the same module or 10 μ s for channels in other modules.

FILTER

Finite Impulse Response (FIR) filtering is provided. Eighty sets of 128 FIR filter coefficients are available in each 7400, providing an extensive selection of filter frequencies and characteristics. The coefficients are user programmable, and each coefficient is 18 bits in length. The filters are loaded with default coefficients providing logical filter cutoff selections and characteristics. The default filter frequencies and characteristics are easily changed using program instructions to satisfy future requirements.

DATA

Data are output in a digital format on the Ethernet interface. The output data is 32-bit floating point format and can be chosen via programming to be Volts, millivolts, microvolts, or user defined engineering units derived from a polynomial expression. Each system can output data from all channels at the maximum sample rate.

PROGRAMMING

All operating parameters can be set and queried using the extensive, built-in command set. Setup information is saved in password protected EEPROM memory on board, and it is automatically restored when power is applied or the system reset. The command set is well documented, and source code programming examples are provided.

SOFTWARE

PI770 is the choice for test management, data acquisition, and data display. Ready to run out of the box it is a 32-bit application that runs on Microsoft Windows operating system. It provides all the tools for test definition, setup and tracking, transducer calibration, data acquisition, display, replay and export, and test quality validation. PI770 comes with an Application Programmer's Interface that greatly reduces the development time for custom operating software. PANEL72 is Pacific's maintenance and calibration software. It may be used to troubleshoot installation problems and calibrate the 7400 modules.

COMMUNICATIONS

Initializing communication with the 7400 is simple. Commands are included that enumerate the 7400 devices on the network. After the enumeration operating software creates a socket interface between itself and each module, simple Send and Receive network commands are used to communicate. Status LEDs that assist with initial setup are located on the connector end of the enclosure.



SPECIFICATIONS

INPUT

Configuration7416: Six-wire input, signal input (2), excitation (2), excitation sense (2) and shield. Programmable bridge completion for half bridges and 120 Ohm and 350 Ohm quarter bridges.. 7418: Two-wire input, signal input (2) and shield. 7420: Four-wire input, signal input (2), transducer power (2) and shield.

Input Impedance ..50 Megohms, shunted by 500 pF.

Input Protection±50 Volts differential, ±50 Volts common mode without damage.

Bridge Balance7416: Automatic by program control. Balance accuracy ±0.05% of range, ±1 mV RTO.

EXCITATION / TRANSDUCER POWER

Voltage Excitation ..7416: Constant voltage with remote sensing. Programmable from 0 to 15 Volts with 1 mV resolution. Calibrated 1-Volt steps ±0.1%. 50 mA limited to 70 mA maximum.

Excitation Regulation ..±0.1% over input voltage range and no-load to full load.

Excitation Stability ..±0.01%, 0.001%/°C

Excitation Noise.....200 µV peak-to-peak, DC to 10 kHz

Transducer Power ..7420: Regulated voltage. Programmable from 1 to 15 Volts in 1V steps. Regulation and stability ±1%

AMPLIFIER

Input Range±10 mV to ±10 Volts.

GainProgrammable from 1 to 1,000 with 0.02% resolution. Thirteen calibrated gain steps are provided: 1, 2, 3, 5, 10, 20, 30, 50, 100, 200, 300, 500, 1000 with ±0.02% accuracy.

Gain Stability±0.01% for 30 days, ±0.001%/°C.

Gain Linearity±0.02%.

Common Mode60 dB plus gain in dB to 110 dB, DC to 60Hz.

CM Voltage±10 Volts operating.

ZeroAutomatic zero to ±2 µV RTI or ±1.0 mV RTO whichever is greater.

Zero Stability±2 µV RTI plus ±1 mV RTO over the full temperature range.

Source Current±40 nA, ±0.4 nA/°C.

Bandwidth100 kHz (-3dB).

Noise (100 kHz)....4.0 µV RTI plus 0.3 mV RTO, RMS.

Crosstalk.....100 dB at 10 kHz

Harmonic Distortion 90 dB at 10 kHz

OverloadRecovery time is 120 µS to within ±0.1% for a 10 times overload to ±10 Volts.

FILTER

TypeFinite Impulse Response (FIR) with 128 coefficients.

Frequency.....Programmable from 10 Hz to 50 kHz with 80 dB/octave attenuation above cut-off.

DIGITIZER

Resolution24-bits, Sigma-Delta type.

RateIndividual channels may be programmed to output data at rates up to 204.8 kHz. Supports all sixteen channels at the highest sample rate.

TIME SYNCHRONIZATION

SourceExternal TTL input or IRIG A, B or G. IRIG G output provided from each 7400 for multiple module synchronization.

Time Alignment.....1 µS using external TTL and 10 µS using IRIG channel to channel and module to module.

OutputDays, Hours, Minutes, Seconds, Microseconds may be output at selected positions in the data stream.

ACCURACY

Accuracy.....The system maintains ±0.05% full scale (2-sigma) uncertainty for gains up to 200 and ±0.1% full scale (2-sigma) uncertainty for gains above 200 over the operating temperature range.

CALIBRATION

ShuntTwo steps, single shunt. Internal or external shunt connection.

Shunt Resistors.....Installed shunt resistors provide 0.502 and 0.250, ±0.1% mV/V for 350 Ohm bridge.

VoltageThe output of a temperature stable, 5-Volt internal reference with ±0.01% stability, X1.0, X0.1 and X0.01 ±0.05% attenuator and 0.0015% resolution on each attenuator setting may be applied to each channel. Accuracy is ±0.2% for gains to and including 100 and ±0.3% for gains over 100. Stability is ±0.01%. Output of the internal reference can be measured on an external connector.

ZeroAmplifier input disconnected and shorted for zero calibration.

INTERFACE / COMMUNICATIONS

Interface.....Gigabit Ethernet, TCP/IP, control and data.

Data FormatFloating point, 32-bits. Output available in engineering units, Volts or millivolts.

OperationSupported by PI770 operational software and PANEL72 maintenance software.

MECHANICAL

ConnectorsMIL, 1/4-turn locking.

Temperature-20°C to +50°C operating. ambient air. -20°C to +40°C operating fully sealed. Extended temperature range using forced air cooling.

VibrationMIL-STD-810F, Category 24.

Shock50 Gs, 11 mS all axis.

MoistureNEMA 13.

Power20 to 30 VDC, 3A

Dimensions.....5.25" Wide, 7.75" High, 12" deep excluding mounting flanges

Weight14 lbs.

ORDERING INFORMATION

741616-Ch Strain/Bridge Data Acquisition.

741816-Ch Voltage Data Acquisition.

742016-Ch Transducer Data Acquisition.